



## M1 HALO EXTENDED



## PRODUCT CONFIGURATION

Please fill in appropriate codes into boxes provided

Power	Flange	Driver	Material	Colour	Accessories
<input type="text" value="M1"/>	<input type="text" value="HE"/>	<input type="text" value="R"/>	<input type="text" value="C"/>	<input type="text" value="27"/>	<input type="text" value="FM"/>
M1 1 Watt	HE Halo Extended	R Remote (series) IA Integral (12VAC)* ID Integral (24VDC)*	C Copper S Stainless Steel A Aluminium* BK Black BZ Bronze W White	27 2700K 30 3000K A Amber R Red	FM Flange Mount

\*Please specify powder-coat colour when ordering an aluminium luminaire.

## SPECIFICATIONS

<b>Power</b>	1 Watt
<b>Ingress Protection Rating</b>	IP66
<b>Cable</b>	H05RN-F 2x 75mm
<b>Material</b>	- Black/Bronze/White Powdercoated - Natural Copper - 316 Stainless Steel
<b>Removable Light Engine</b>	Push mounted 1W Cree XPG-3 LED
<b>Colour Temperature</b>	2700K, 3000K, Amber, Red
<b>CRI</b>	90+ CRI
<b>Efficacy</b>	80lm/w - Delivered from luminaire with unobstructed beam
<b>Input</b>	350mA Constant Current (Remote) 12V AC (Integral) 24V DC (Integral)
<b>Warranty</b>	Electronics - 5 Years Aluminium - 5 Years Copper - 10 Years Stainless Steel - 10 Years
<b>LED Life Expectancy</b>	50,000 Hours
<b>B Number</b>	94.05

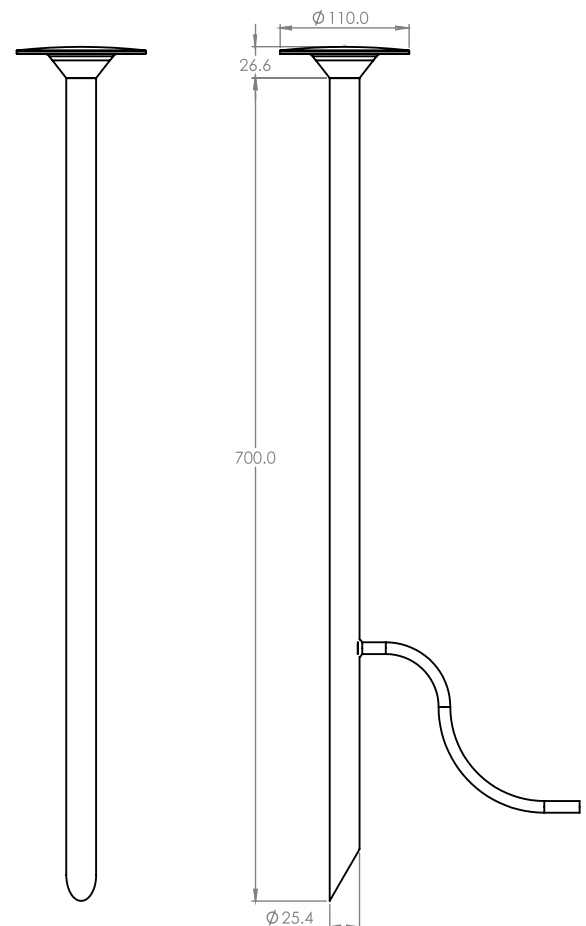

## ACCESSORIES

Surface mount flange  
(Please refer to the accessories page)

[www.luxrled.com](http://www.luxrled.com)

## M1 HALO EXTENDED

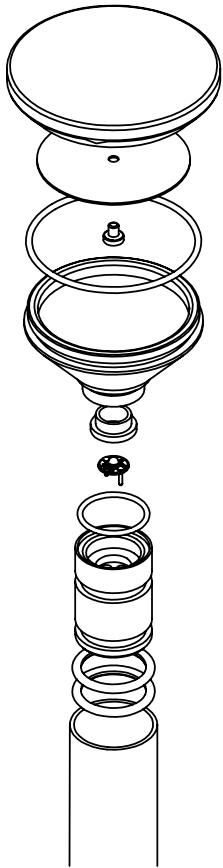

### REPLACING COMPONENTS

Firstly, pull the head of the product out of the pole. Unscrew the lens from the body, paying close attention to the assembly order or refer to the diagram. Locate the item that needs to be replaced, it is imperative you replace the component with factory LuxR parts to ensure correct operation of the luminaire. When reassembling, make sure all the components are in their correct order to ensure water tightness and correct light output.

### RECOMMENDATIONS

If you are unable to spike this luminaire into gardens or along side paths you can specify this product with a surface mount flange. This allows the user to mount the luminaire where it is not possible to spike it in, such as concrete.

### BEAM ANGLES

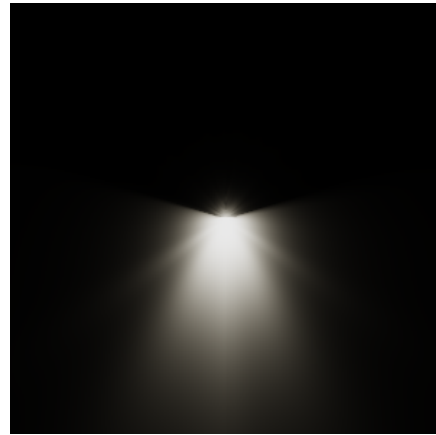

### M1 HALO

The M1 luminaire range is powered by a 1 watt LuxR light engine that offers a wide choice of LED colours. The luminaire was developed to meet the challenge of delivering high quality practical accent lighting with maximum energy efficiency and a long, maintenance-free life.

All LuxR luminaires offer a replaceable LED system using Cree LED chips for maximum performance and long life. Precise LED binning by Cree ensure the same colour temperature across all our luminaires which allows LuxR products to be situated close to one another without the fear of colour variance in the colours.

This luminaire is extremely tough, durable and waterproof, making it ideal for installation in public spaces, large-scale projects and residential areas.

### REMOTE DRIVER WIRED IN SERIES

Often referred to as series wiring, the current in a series circuit follows one path from start-to-finish with the positive of the second LED connected to the negative of the first. Series wiring allows a single driver to be mounted remotely, powering a number of series fittings. Often the most simplest of wiring schemes as each fitting is connected to the next in a daisy chain. It removes the need for a 12 volt driver in each fitting.

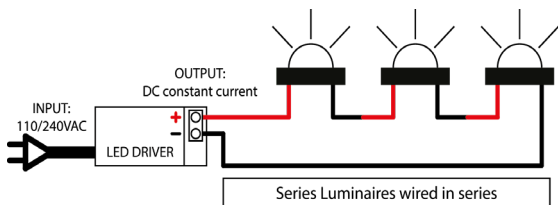

### INTEGRAL (12VAC-24VDC) + 12VAC TRANSFORMER / 24VDC POWER SUPPLY

In a parallel circuit, the positive connections are tied together and brought back to the positive output of the 12VAC Transformer / 24VDC Power Supply. The negative connections are tied together and brought back to the negative output of the 12VAC Transformer / 24VDC Power Supply. The integral driver option allows LuxR fittings to be wired in parallel to existing or new installations where a wire wound or magnetic 12VAC Transformer or 24VDC Power Supply is used.

