

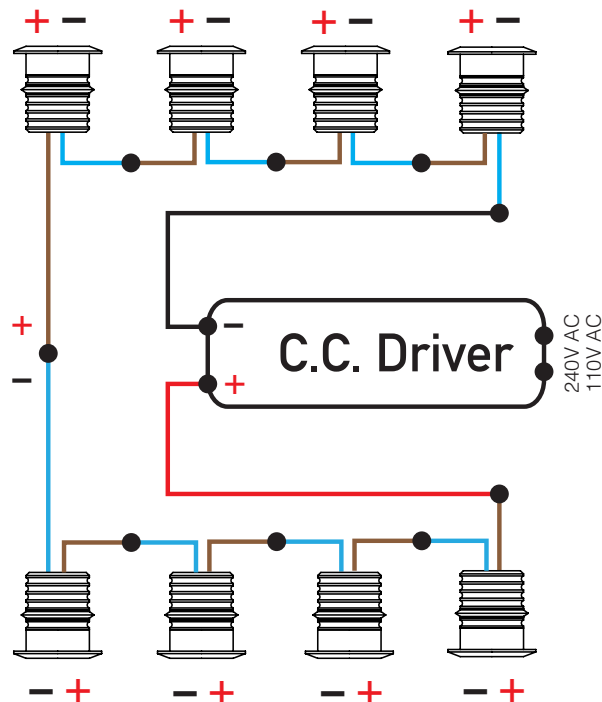

SERIES WIRING SCHEMATIC



INSTALLATION INSTRUCTIONS

To preserve the validity of your warranty and ensure long term performance of your LuxR products, it is critical to follow the correct installation procedures.

The installation of LuxR Modux range of luminaires must be carried out by a suitably qualified person in accordance with local and/or international standards. When working on an electrical system all precautions should be taken to prevent electrical shock.

When the driver device has been switched off there a residual voltage, which can be apparent for up to 10 minutes. Connecting LEDs to a driver device within this time, without first discharging the secondary output will damage the LED's. To prevent damage of the LED, ensure that the circuit is switched off and the driver is not live, before connecting any LED's.