

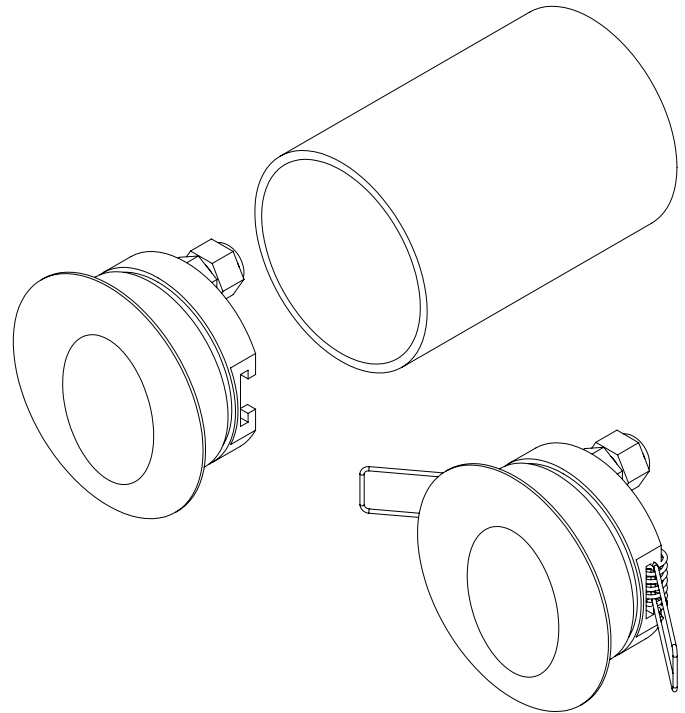

V1 ROUND INSTALLATION GUIDE



Canister installation instructions:

For mounting into masonry (block) walls outdoors: Mark out intended positions and centre spacing between luminaires directly onto the wall. Simply core a 70mm (2 3/4") hole in the wall. Apply PVC cement to the canister and roll it in sand, this creates a key for the plaster/cement to adhere to the canister. The canister is then plastered/concreted into position completely encapsulating the PVC canister on all sides except the opening where the luminaires fit. The flange should then recess flush with the mounting surface.

Indoor installation instructions for coil spring retainers:

For mounting into plasterboard wall indoors, a canister is often not necessary. In this case order the product with coil spring retainers fitted: Place masking tape onto the wall in the intended areas. Mark out positions and centre spacing between luminaires directly onto the tape. Using a hole saw, cut a 63.5mm (2 1/2") hole in the wall. Install the series wired cabling from the driver, and to all subsequent cut-outs in the series circuit. Bend the coil springs back and install the luminaire into the hole that has been made. The spring legs will secure it in place.

Install the wired cabling from the driver, and to all subsequent cut outs in the series circuit. All connections must be IP rated with double-wall heat shrink insulation. Install the luminaire into the canister. The O-Ring around the body will secure it in place. Connect in series. IP68 connector recommended. Never switch the output of a constant current driver. Driver must be switched off when connecting LED's to prevent damage.

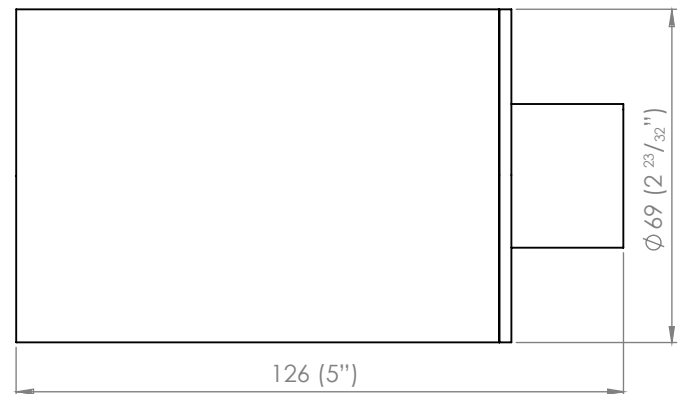

REMOTE DRIVER WIRED IN SERIES

Often referred to as series wiring the current in a series circuit follows one path from start-to-finish with the positive of the second LED connected to the negative of the first. Series wiring allows a single driver to be mounted remotely, powering a number of series fittings. Often the most simplest of wiring schemes as each fitting is connected to the next in a daisy chain. It removes the need for a smaller 12 volt driver in each fitting.

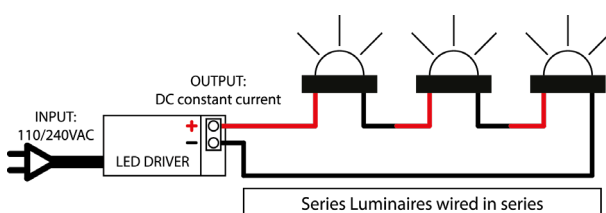

INTEGRAL DRIVER + TRANSFORMER

In a parallel circuit all the positive connections are tied together and back to the positive output of the LED driver and all the negative connections are tied together and back to the negative output of the driver. The integral driver option allows LuxR fittings to be wired in parallel to existing or new installations where a wire wound or magnetic transformer is being used.

